

# Thermador®

## Care and Use Manual

for

**UNIVERSAL COOK‘N‘VENT® DOWNDRAFT SYSTEM**

**30" MODELS - CVS30R • 36" MODELS - CVS36R**

**45" MODELS - CVS45R**

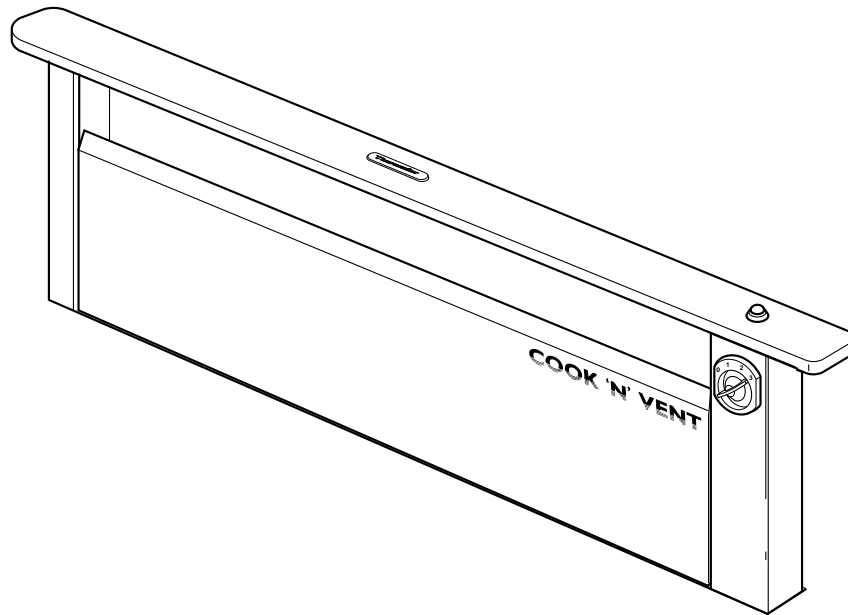

### TABLE OF CONTENTS



Safety Instructions ..... 2



Operating Instructions ..... 3-4  
Features ..... 3  
Operation ..... 4



Care and Cleaning ..... 5-6



Consumer Services  
Warranty ..... 7

Before Calling for Service...Back Cover  
How to Obtain Service.....Back Cover  
Data Plate Information.....Back Cover



# IMPORTANT SAFETY INSTRUCTIONS

Read All Instructions Before Using the Appliance.

## **WARNING - TO REDUCE THE RISK OF A COOKTOP GREASE FIRE:**

- A.** Never leave surface units unattended at high settings. Boil-overs cause smoking and greasy spillovers that may ignite. Heat oils slowly on low or medium settings.
- B.** Always turn hood ON when cooking at high heat or when cooking flaming foods.
- C.** Clean ventilating fans frequently. Grease should not be allowed to accumulate on fan or filter.
- D.** Use proper pan size. Always use cookware appropriate for the size of the surface element.

## **WARNING - TO REDUCE THE RISK OF INJURY TO PERSONS IN THE EVENT OF A COOKTOP GREASE FIRE, OBSERVE THE FOLLOWING:**

- A. SMOTHER FLAMES** with a close-fitting lid, cookie sheet, or metal tray, then turn off the burner. **BE CAREFUL TO PREVENT BURNS.** If the flames do not go out immediately, **EVACUATE AND CALL THE FIRE DEPARTMENT.**
- B. NEVER PICK UP A FLAMING PAN.** You may be burned.
- C. DO NOT USE WATER,** including wet dish cloths or towels. A violent explosion will result.
- D. Use an extinguisher ONLY if:**
  - 1) You know you have a Class ABC extinguisher, and you already know how to operate it.
  - 2) The fire is small and contained in the area where it started.
  - 3) The fire department is being called.
  - 4) You can fight the fire with your back to an exit.



# FEATURES

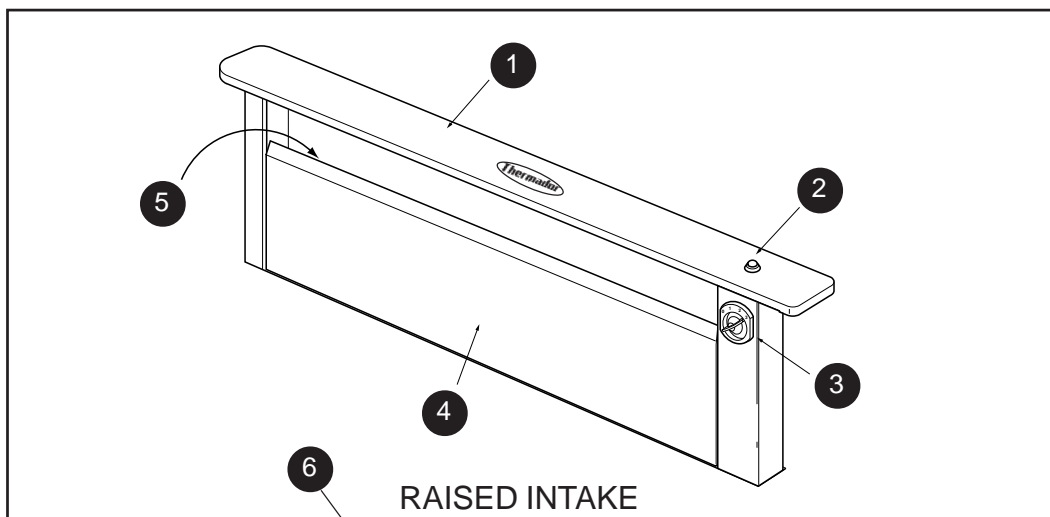

- 1 Intake Top Cap
- 2 UP/DOWN Push-button
- 3 Blower Speed Control Knob
- 4 Front Panel
- 5 Filters (behind front panel)
- 6 Blower (not shown)

The Thermador Universal Cook'n'Vent® takes the place of an overhead hood and can be conveniently hidden away (lowered) when not in use.

There are five primary parts of the Universal Cook'n'Vent® downdraft system that will be referred to in this booklet: The Intake, the UP/DOWN Push-button, the Blower, the Blower Speed Control Knob and the Filters.

## The Intake

The intake, when raised, captures and channels the cooking odors, steam and grease. The filters are located within the intake.

## UP/DOWN Push-button

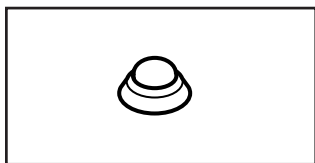

The UP/DOWN push-button is located on the top right of the intake. Press the push-button once to raise or lower the intake. **It is not necessary to hold the push-button.**

## The Blower

The blower is the fan that draws the cooking odors out of the house.

## The Blower Speed Control Knob

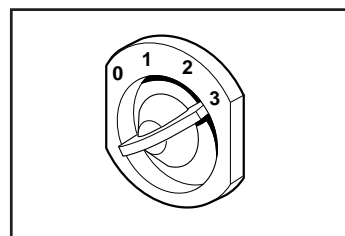

The blower speed control knob is located on the right front of the intake. The intake must be raised in order to use the control knob. There are four blower speed settings represented by numbers "0" (Off), "1" (Low), "2" (Medium), and "3" (High).

## Filters

The filters are located just behind the removable front panel with the Intake. The filters condense and trap the grease in the air.



# OPERATION

## For Best Results

- Turn the blower on before starting to cook.
- A higher heat setting may be needed when the Cook'n'Vent® is in operation.
- Use a rear burner when browning or pan frying meat.
- Open a window or inside door slightly.
- Clean the intake front panel and back wall and filters after each use.

**For Gas Cooktops**, a lower blower speed should be used if:

- the gas flame is being distorted by the air movement,
- the burner continually sparks (clicks), or
- the burner flame repeatedly blows out.

## To Raise the Intake

- Press the UP/DOWN push-button once to raise the intake.
- The intake will stop automatically at its maximum height.
- The blower will automatically turn on to the previously set blower speed.

## To Set or Adjust Blower Speed

- Vary the blower speed as needed for the food or the cooking method being used. For example: greasy or pungent foods require greater ventilation power than boiling pasta.

## To Lower the Intake

- Press the UP/DOWN push-button once.
- The blower, if operating when the UP/DOWN push-button is pressed, will turn off when the intake is lowered.

## To Stop Intake While It is Moving

Press the UP/DOWN push-button once.

- The intake will stop.
- Press the UP/DOWN push-button again to complete the cycle.

# CARE AND CLEANING



The efficiency of the Cook'n'Vent® downdraft ventilation system depends on the cleanliness of the intake and filters. The frequency of cleaning depends on the amount and type of cooking.

- Do not use the ventilating system without the filters in place or with grease-laden filters or surfaces.

## To Clean the Intake

**Intake must be in the raised position to clean.**

- Turn Off the blower ("O").
- Grasp the removable front panel at the top near the sides and pull up and then forward. Set aside.
- Remove filters.

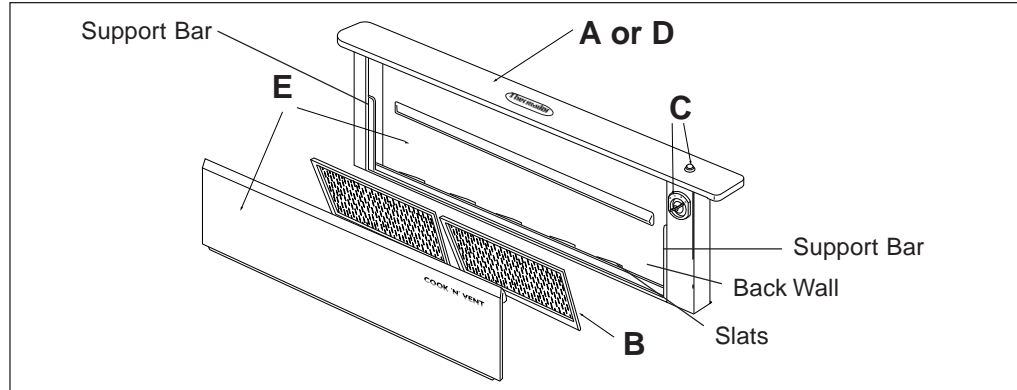

- Always use the mildest cleaner that will do the job. Use clean, soft cloths, sponges or paper towels.
  - Rub stainless steel finishes in the direction of the grain. Wipe area dry to avoid water marks.
  - After cleaning, place all parts in their proper positions before using the Cook'n'Vent®.
- The cleaners recommended below indicate a type and do not constitute an endorsement. Use all products according to package directions.

<b>A</b>	<b>Anodized Aluminum</b> Top Cap for Stainless	Top cap is not removable. Wash top and underside with hot sudsy water. Rinse and wipe dry or apply Fantastic® or Formula 409® first to a clean sponge or paper towel and wipe clean. <u>DO NOT USE powdered cleansers or steel wool pads.</u>
<b>B</b>	<b>Aluminum</b> Mesh Filters	Clean filters in the dishwasher or by agitating in sudsy water. Ensure that there is no soil trapped in the fine mesh. Dry the filters before reinstalling them.
<b>C</b>	<b>Plastic</b> UP/DOWN Push-button, Control Knob	DO NOT REMOVE push-button or control knob. Wipe with a moist soapy sponge. Rinse and dry.
<b>D</b>	<b>Painted</b> Top Cap for Black/White	Top cap is not removable. Wash top and underside with hot sudsy water. Rinse and wipe dry or apply Fantastik® or Formula 409® first to a clean sponge or paper towel and wipe clean. <u>DO NOT USE powdered cleansers or steel wool pads.</u>
<b>E</b>	<b>Stainless Steel</b> Front Panel & Back Wall	Wipe grease accumulation with a paper towel or sponge. Scrape heavy buildup with a plastic spatula. Clean with a soapy sponge; rinse and dry. Always wipe or rub with grain. Wipe with Fantastic® or Formula 409® <b>sprayed onto a paper towel</b> . If grease buildup is heavy, several applications may be necessary. Polish with Revere Ware® Metal Polish or Stainless Steel Magic® and a soft cloth. Remove water spots with a cloth dampened with white vinegar. Use Revere Ware® Instant Stainless Steel Cleaner to remove heat discoloration.

## To Re-Assemble the Intake

- Place the filters inside the intake, side by side, on the slats in front of the back wall. They will lean forward and the tops of the outside two will rest against the support bars.
- Holding the front panel at the top near the sides, place bottom edge over front lower sill of the intake.
- Keeping the panel vertical, hook the top of the front panel to the intake.



# CARE AND CLEANING

## OCCASIONAL COOK'N'VENT® CARE

Approximately every six months, remove any food soil that may have collected behind the access panels. The 30" and 36" models have two removable access panels; the 45" model has 3 panels.

The access panels to the "clean out" area are beside the blower (cabinet installation) or duct transition (re-

mote blower installation). See illustration below. The electrical connection box above the clean out area must be accessible for electrical inspection or service only. **DO NOT TOUCH OR CLEAN** the electrical connection box.

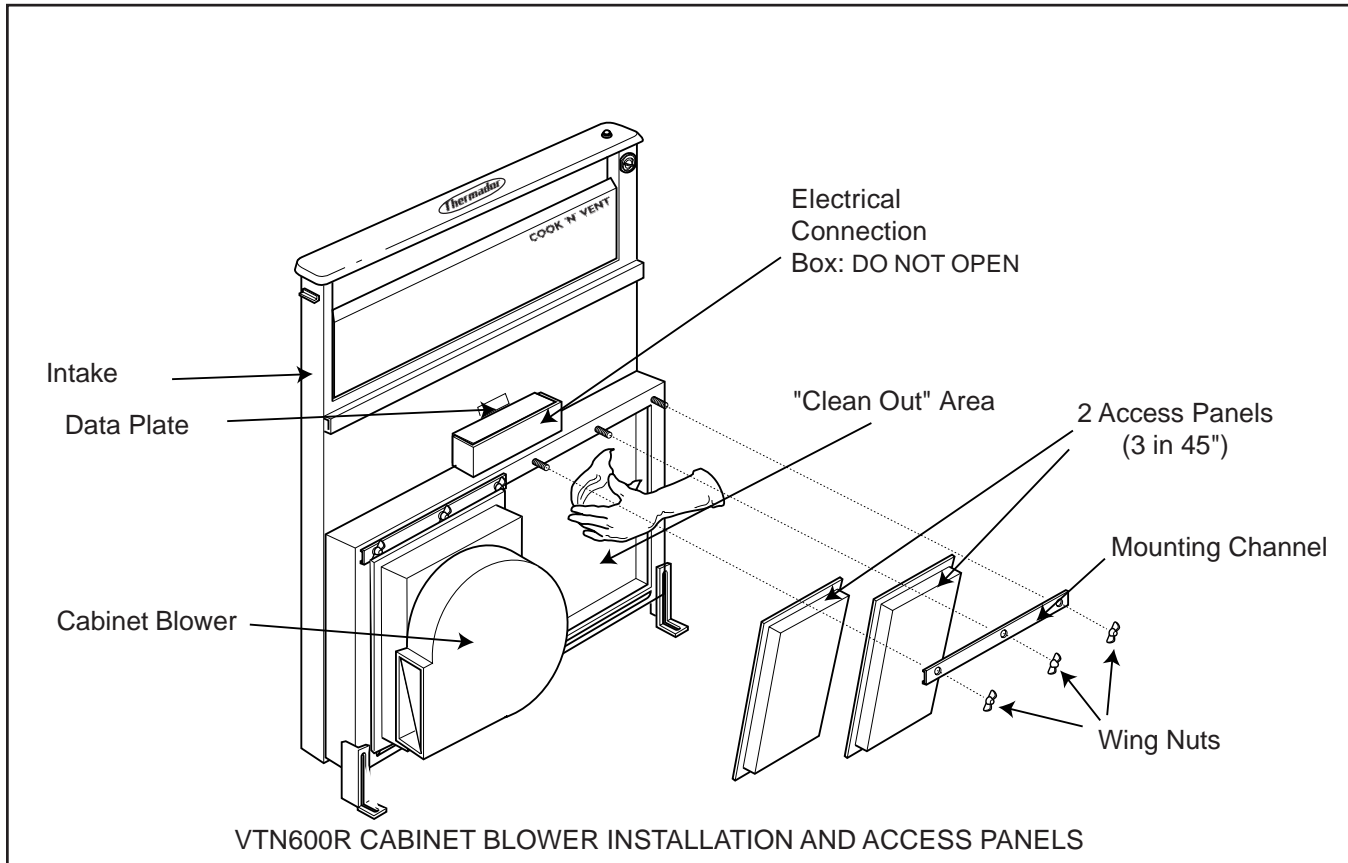

## TO REACH THE CLEAN OUT AREA

1. Unplug the electrical cord for the Cook'n'Vent®.
2. Unscrew the wing nuts on the top of the access panels as illustrated above. Lift out mounting channel and panels.
3. Avoid the electrical connection box above the access panels. Be careful when working around the metal framework of the "clean out" area as there may be sharp edges.
4. Wipe up any accumulated grease or food in the "clean out" area. Use a general household degreasing spray or cleaner. Rinse and dry.
5. Replace the access panels and mounting channel. Tighten the wing nuts securely.
6. Plug in the electrical cord for the Cook'n'Vent®.



# CUSTOMER SERVICES WARRANTY

## THERMADOR® COOK'N'VENT® WARRANTY CVS30R, CVS36R AND CVS45R

### WHAT IS COVERED

#### Full One Year Warranty

For one year from the date of installation or date of occupancy for a new previously unoccupied dwelling, any part which fails in normal home use will be repaired or replaced free of charge. Save your dated receipt or other evidence of the installation/occupancy date.

Thermador® will pay for all repair labor and replacement parts found to be defective due to materials and workmanship. Service must be provided by a Thermador® Authorized Service Agency during normal working hours.

### WHAT IS NOT COVERED

1. Service by an unauthorized agency. Damage or repairs due to service by an unauthorized agency or the use of unauthorized parts.
2. Service visits to:
  - Teach you how to use the appliance.
  - Correct the installation. You are responsible for providing electrical wiring and other connecting facilities.
  - Reset circuit breakers or replace home fuses.
3. Damage resulting from accident, alteration, misuse, abuse, improper installation or installation not in accordance with local electrical codes or plumbing codes, or improper storage of the appliance.
4. Repairs due to other than normal home use.

### WARRANTY APPLICATION

This warranty applies to appliances used in normal family households. It does not cover their use in commercial situations.

This warranty is for products purchased and retained in the 50 states of the U.S.A., the District of Columbia and Canada. The warranty applies even if you should move during the warranty period. Should the appliance be sold by the original purchaser during the warranty period, the new owner continues to be protected until the expiration date of the original purchaser's warranty

period.

THERMADOR® DOES NOT ASSUME ANY RESPONSIBILITY FOR INCIDENTAL OR CONSEQUENTIAL DAMAGES. Some states do not allow the exclusion or limitation of incidental or consequential damages, so the above limitation or exclusion may not apply to you. This warranty gives you specific legal rights and you may also have other rights which may vary from state to state or province to province.

### SERVICE DATA

For handy reference, the serial tag information has been affixed to the back cover. For location of the serial tag

on the product see the back cover. Keep your invoice for warranty validation. To obtain service, see back cover.



# CUSTOMER SERVICES

## BEFORE CALLING FOR SERVICE

- Ensure that the electrical cord is properly connected and the supply circuit is energized.
- If the blower does not operate:**
- Check that the intake is fully raised.
  - Make sure that the blower speed control knob is not in the OFF position, "0".

## HOW TO OBTAIN SERVICE

**For authorized service or parts information, call 1-800-735-4328.**

We want you to be a satisfied customer. If a situation arises that has not been resolved to your satisfaction, please let us know.

Write: Customer Support, Thermador®, 5551 McFadden Ave., Huntington Beach, CA 92649, or call: 1-800-735-4328.

Please include the Model Number, Serial Number (listed below), and Date of Original Purchase/Installation.



Serial Number/Data Plate Location: Above Electrical Connection Box. See Page 6.

We reserve the right to change specifications or design without notice. Some models are certified for use in Canada. Thermador® is not responsible for products which are transported from the U.S. for use in Canada. Check with your local Canadian distributor or dealer.



***Thermador***®  
**BSH Home Appliances Corp.**

5551 McFadden Avenue, Huntington Beach, CA 92649 • 800/735-4328  
ECO 71602 • 5060002295 • 19-12-202E • © 2003 BSH Home Appliances Corp. • Litho in U. S. A. 5/03